

Name: _____

Goal: Explain a quotation

"If the automobile had followed the same development cycle as the computer, a Rolls-Royce would today cost \$100, get a million miles per gallon, and explode once a year, killing everyone inside."

--Robert X. Cringely, InfoWorld Magazine

Charles and Frank Duryea were the first Americans to build a successful automobile, and the first to incorporate an American business for the express purpose of building automobiles for sale to the public. On this day that we remember Frank's birthday, consider the quote from InfoWorld Magazine above. Write an essay in which you explain this quotation. To help you get ready to write, answer the following questions.

1. Rewrite this quotation in your own words.
2. How does the development of the computer compare with the development of the automobile?
3. List five ways the automobile would be different if it had followed the same development cycle as the computer.

Now you are ready to write your essay.

Name: _____

Read the entire paragraph. Then use the information in the paragraph to help you draw and color the image.

Visiting my grandparents' farm is the best part of my summer. They have a big red barn with a white "X" going from corner to corner. Next to the barn is a fenced-in corral with a horse in it. The sky is always a bright blue with just a few wispy clouds high up. I love standing at the fence with my little gray dog next to me as I wait for the horse to come over and take the apple that I offer to him.

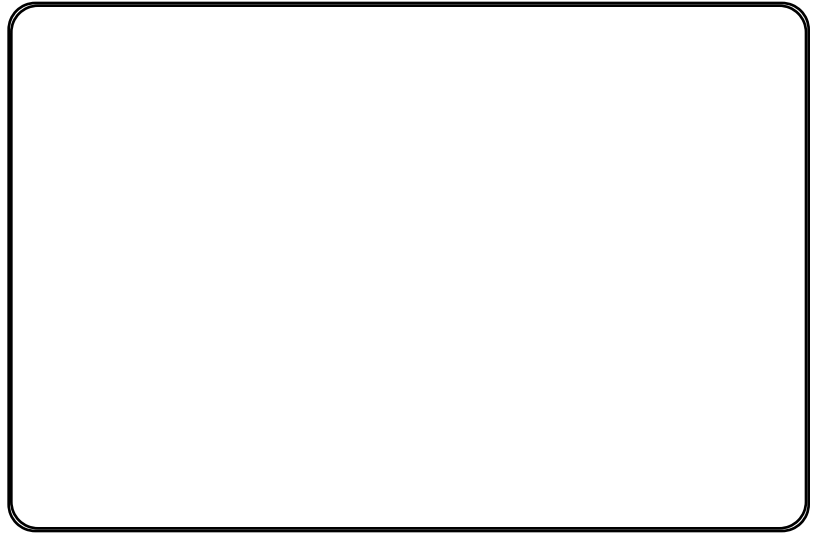

Draw a picture of the speaker's grandparents' farm.

What happens next?

Each word is missing two letters. Fill in the missing letters to complete each word.

hibern _____ e

ran _____

c _____ sider

vict _____

un _____ ad

lunc _____ oom

_____ ick

fe _____ t

_____ ack

exquisi _____

Name: _____

Goal: Write a journal entry

President George Washington chose the site; however, John Adams and his wife would be the first to occupy the executive mansion. In her journal, his wife, Abigail, wrote about their new home: "I pray heaven to bestow the best of blessings on this house, and on all that shall hereafter inhabit it. May none but wise men ever rule under this roof!" Imagine you are living in 1792, when the building began. Write a journal entry about this important day in history as if you were there when it all happened. To help you get ready to write, plan your journal entry below.

1. Where are you that day? Describe the setting.
2. How was this day just like any other day?
3. How was this day different from any other day?
4. What three things do you see this day?
5. What do you like most about this day?
6. What do you like least about this day?
7. How do you feel about this day?

Now you are ready to write your journal entry.

Name: _____

Goal: Use the conventions of storytelling (plot, character, setting) to tell a story

Write a story that has a character who has been accused by The House Un-American Activities Committee (HUAC) of the U.S. Congress. To help you get ready to write, plan your story below.

- 1. Who is the main character?
- 2. List three describing details about the major character.
- 3. What is the major conflict or problem the character has?
- 4. What does the character do to solve the problem?
- 5. Tell three events that happen in the story.
- 6. How does the story end?

Now you are ready to write your story.

Name: _____

describing words:	television abstract	feisty rickety	freezing goeey
--------------------------	------------------------	-------------------	-------------------

who or what?	picture lawyer	porridge noodles	tarantula painting
---------------------	-------------------	---------------------	-----------------------

did what?	was found unpacked	selected hung	winked astounded
------------------	-----------------------	------------------	---------------------

where?	on the wall down the hall	on half of it	in the stadium on the set
---------------	------------------------------	---------------	------------------------------

when?	during the blizzard		
		at the race	after its bath

How many sentences can you write? Use some of the ideas from above.

How many total legs are on 6 elephants?

How much greater is 173 than 48?

$$15 + \underline{\quad} + 20 = 51$$

A, E, I, M, Q,
_____, Y

65, 78, 91, _____, 117,
130, 143

In the equation $30 \times 405 = 12,150$, which number is the product?

Name: _____

Use each of the blocks to spell four words.
Hint: Use the words kisses and tasty.

S	S	U	E	M	S	I	I	Y	
C	O	T	E	N	T	Y	S	T	A
	O	K	E	N		E	N	K	

1.								
2.								
3.				T				
4.				K	E			

Circle the spelling words.

outfitdoughnutslavewolfunablenourishmonkeykisses
 doughnutnourishrepresentmonkeyreachedwolfoutfit
 representslavewolfdoughnutfinaloutfitunablekisses

Draw one line to find two spelling words in each puzzle. The bold letters start each word.
 You can move left, right, up, or down. Write the two words that you find.

W O A V J P A L
 O E O E H E U U
 W A Q E O G I A
 K B C J B I E O
 E E N O M P Z X
 U O A O G H S I
 N **U** G E V C B Q
 A B L E **L** I M E

A U A E A V R D
 U S X O A M E B
 A E T E Q D X R
 U A U G W E E U
 F T **W** E U I U K
 B I E A V Y A U
 F W H I E L Y O
 K L U X **U** G E O

Z N **M** O E Y H K
 J N D N K **T** A E
 E O Z A O U S J
 T A D C E B T Z
 F Y Z R P N Y G
 N C M A Q A D I
 P I C Z I K X Q
 T O L S T T L B

Name: _____

Try to spell some words.

ug • ~~at~~ • we • ly • ave • fit • ber • ~~ou~~ • st • ngt
 hen • ~~ghn~~ • ch • out • re • am

doughnut _____

Write the hidden word. Start at one letter and then move either left or right. Continue in same direction.

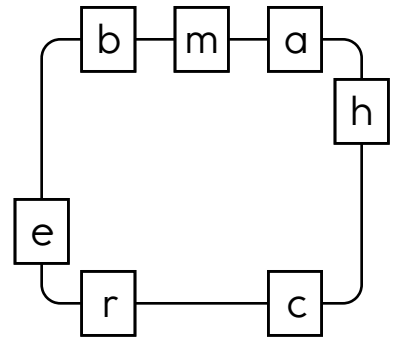
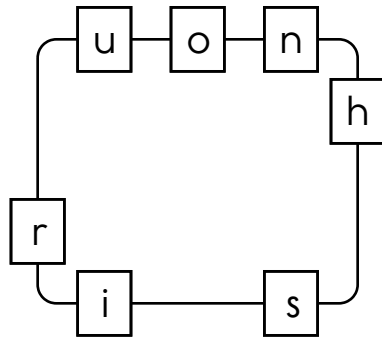
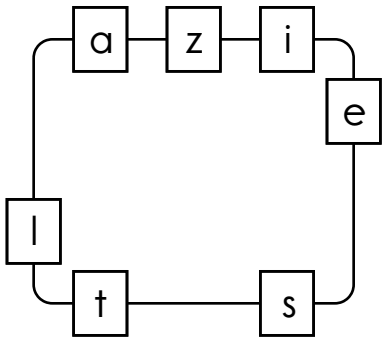

Circle the spelling words.

doughnutweavewolfmonkeyendedrefineunablefinal
 unablecontinuerereachedcactusdoughnutendedslave
 unableslaveunablecontinueunableendedreached

Write a fraction to represent what is shaded.



Mary and Sarah ran a race. Mary came in fiftieth place. Sarah was five runners after Mary. Write the ordinal number for the place that Sarah came in.

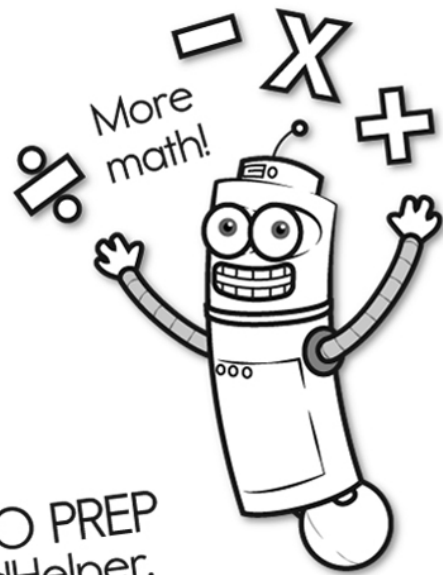
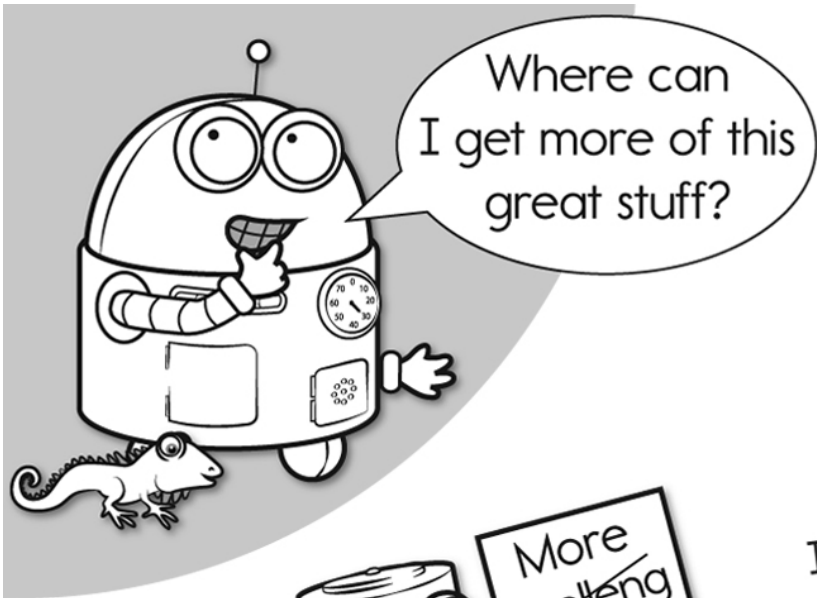

It's NO PREP at edHelper.

More history!

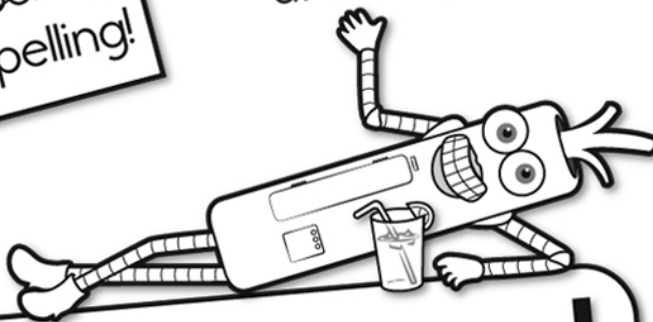

edHelper.com!

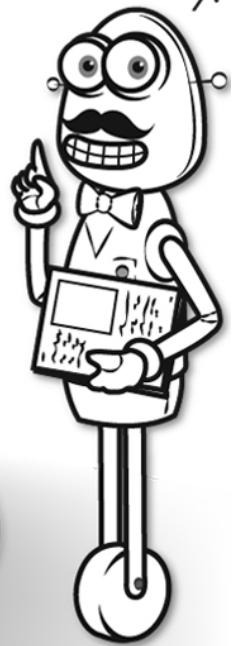

New online math games!

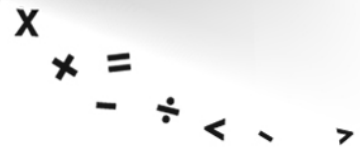
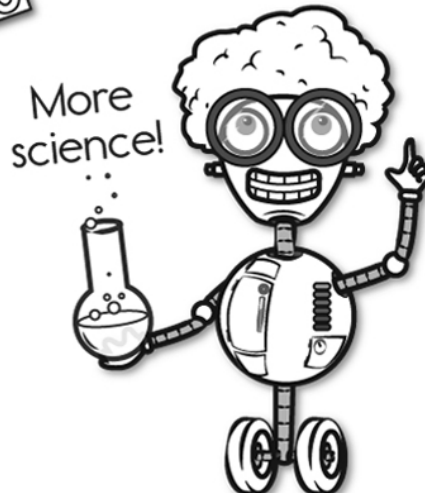
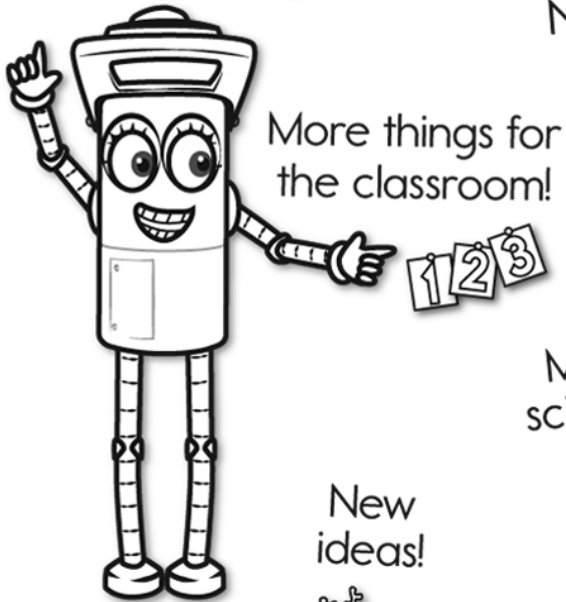

More puzzles!



New ideas!

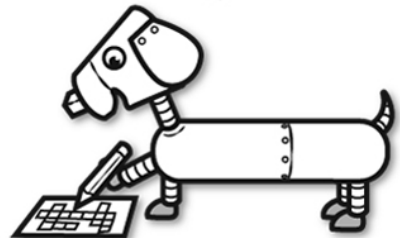

Take The Boring Out Of Homework!

Easy to
print!

edHelper

Weekly K-6 "Take It Home" Books

Kids want choices
for homework.
"Take It Home" books
have fun graphics and
challenging puzzles and
problems for older kids.

"Dr. Programmer"
challenges kids..

Homework
will never be
the same!

edHelper.com

